



US Import & Distribution



*Multi-directional Mini-Sideloader / Reach Truck.
High tech solutions, quality and innovation.*



Q Series FR 20 - 25





Established in 1947, with over 60 years of field experience, the name FIORA is well known as a leading Italian company specializing in the design and construction of 4 way and multi-directional side-loading forklifts.

The modern 100,000 square foot manufacturing facility is home to the metal shop, vehicle assembly, final testing and quality control.

FIORA has always been an innovative leader, by adopting and developing custom solutions with high tech integration. FIORA was the first company to offer cushion rubber wheels, together with a suspension balanced chassis to provide a smooth & stable operation on uneven floors or pavement.



Technology and Development



Multifunctional proportional joystick for the control of hydraulics and steering program selection. Rigid mast made from manganese extruded steel.



Easy access for quick maintenance with onboard diagnostics provided via the Can Bus connected components.



Currently FIORA is the only company to use absolute value weather proof encoders for the control and management of the steer axes.

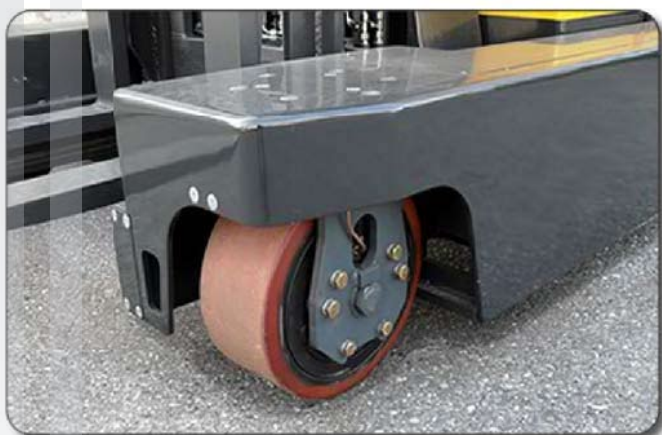

Innovation and Quality

Our technical department specializes in the mechanical, hydraulic and electronic design of custom machines. Solid three point frame base supports work on uneven floors. The large color LCD display, angled toward the operator provides constant real-time vehicle status.

The spacious ergonomic cab offers the operator wide visibility for the all around 360 travel capability of the vehicle. Automotive style foot pedals for travel & braking for intuitive control. Fitted with powerful ~AC motors and controls and energy recovery braking.

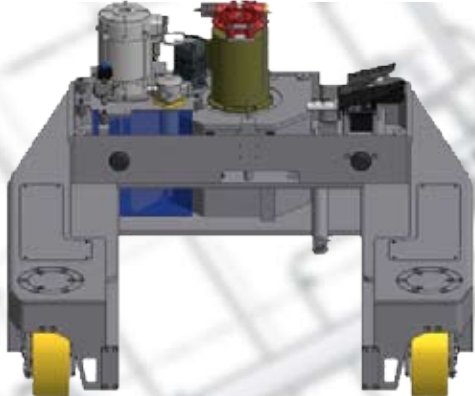

Cab	Spacious with fully adjustable seating
	Integrated arm rest steering wheel
	Pin Code key-less ignition
	Multifunction proportional joystick
	Large LCD color operator console
	~AC motors and controls
	Hydraulic battery movement
	Automotive style pedals
	Electro-hydraulic 360 degree steering
	Open CAN-BUS wiring & diagnostics



All Wheel Steering



The large diameter vulkollan wheels and 7 base selectable steering programs make driving enjoyable.

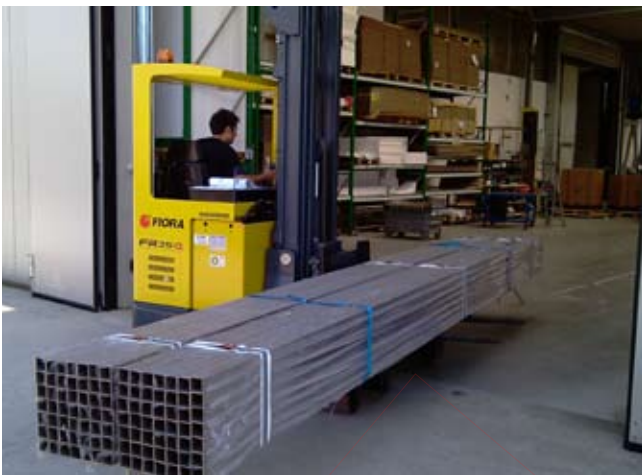

Side travel while steering all wheels



Circular travel pivots around the vehicle center



Forward / reverse travel steering all wheels after accessing aisle sideways



Basic forward / reverse travel with fixed load wheels



Specifications

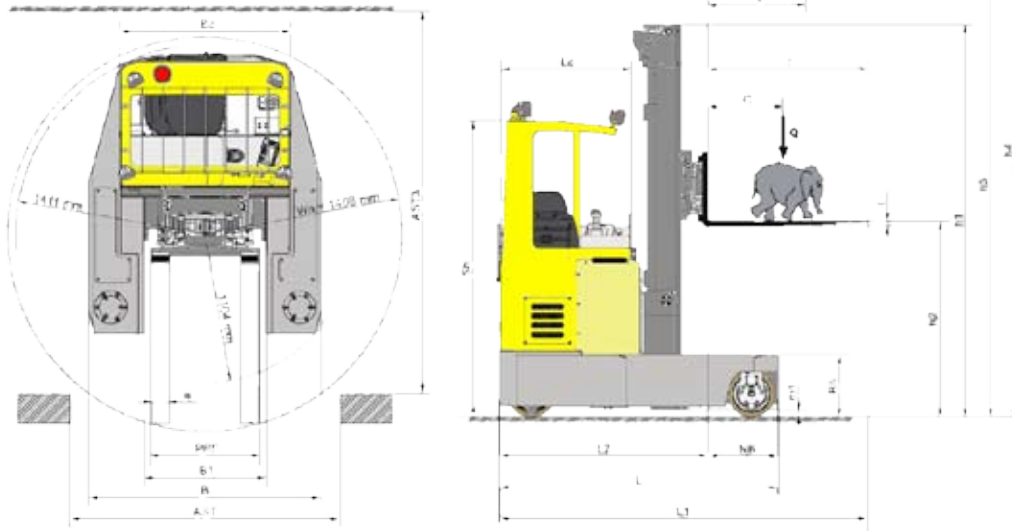

Features	1	Nominal load capacity	Q	kg	[lb]	4400 - 5500 lb
	2	Fork length	l	length	[in]	32 - 63"
	3	Load Centre	C	to fork face	[in]	24"
	4	Load Bed	NB	standard	[in]	21"
	5	Lift Height	h3	standard	[in]	138 - 295"
	6	Number of Wheels		load / traction		2 / 1
	7	Tilt - fork carriage		fwd / back	[deg]	-2 / +4
Dimensions	8	Dimensions std load bed PPF	L	chassis length		81.9"
	9	Overall length with forks	L1			L2+I
	10	Inner distance - load bed	B1			35.4"
	11	Fork carriage std	PPF			31.5"
	12	Chassis to fork face	L2			60.7"
	13	External dimension load bed	B			68.5"
	14	Height load bed from ground	Rh			18.2"
	15	Height of OHG	Sh			86.9"
	16	Under clearance	m1			2.1"
	17	Reach Stroke	V			27.2"
	18	Intersecting Aisle	AST3	w.o. guide rails		23.6" + L1
Speeds	19	Travel w / w.o. load			[mph]	4.35 / 5.6
	20	Lift w / w.o. load			[fpm]	40 / 59
	21	Lower w / w.o. load			[fpm]	59 / 49
	22	Max gradeability w / w.o. load			[%]	8 / 10
Miscellaneous	23	Battery			[V]	48
	24	Battery capacity			[Ah]	700
	25	Average wt w. std battery			[lb]	13225 lb
	26	Load wheels		dia x width		13.5 x 5.5"
	27	Traction wheel		dia x width		13.5 x 5.5"
	28	Traction Motor			[kW]	6 kW
	29	Hydraulic Motor			[kW]	12 kW
	30	Max work pressure			[bar]	180
	31	Service brake		with energy recovery		
	32	~ AC stepless controls				
	33	All wheel 360 power steer		7 prog functions		
	34	Vertical gear box		ring & pinion		



Product Range

Multi-directional travel



Reach Mast



Sideloader with forward facing or side facing cab



Man-up

Four Way travel



Walkie Side travel



Walkie Reach Mast



Very Narrow Sideloader



Order Picking

Automotive travel



Dual Order Selector

Four Way travel



Diesel - LPG

Innovation and Design



FIORA's commitment to partner with their customers, provides the basis of custom solutions. Overcoming the traditional customer - supplier relationship and addressing material handling logistical problems together. "We truly believe, that collaboration is the only way to achieve innovation and constant product improvement to meet the goals and objectives of our customers." - Roberto Fiora

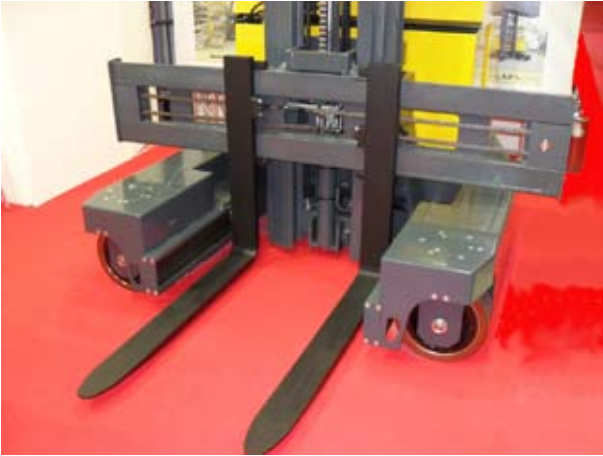

Lateral Handling Specialists.

Customize your lift with many available options or let our sales engineers assist you with the design of a custom built vehicle

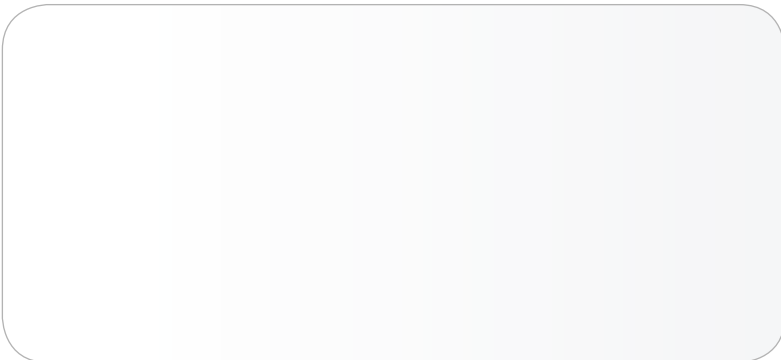

Local Sales & Service provider



US Import Distributor
Professional Materials Handling Co., Inc.
Orlando, FL - 32807 USA
Tel. 407.677.0040 - Fax 407.678.0273
www.pmh-co.com - email: info@pmh-co.com